

User Manual



CM675IR

TRMS 600A AC/DC Clamp with IR Thermometer





Introduction

Congratulations on your purchase of the CM675IR 600A AC/DC True RMS Clamp Meter. This meter measures AC/DC Voltage, AC/DC Current, Resistance, Capacitance, Frequency, Diode Test, Continuity, Type k thermocouple thermometer plus Non-Contact IR Temperature. This device is shipped fully tested and calibrated and, with proper use, will provide years of reliable service.

Content	Page
1.Safety.....	4
1-1.International Safety Symbols.....	4
1-2.Safety Notes.....	4
2.Description.....	5
2-1.Meter Description.....	5
2-2.Symbols Used on LCD Display.....	6
3.Button Function.....	7
4.Operation.....	8
4-1.AC/DC Current Measurement.....	8
4-2.DC Voltage Measurement.....	9
4-3.AC Voltage Measurement.....	10
4-4.Resistance Measurement.....	11
4-5.Diode Test.....	12
4-6.Continuity Measurement.....	13
4-7.Capacitance Measurement.....	14
4-8.Frequency & % Duty Cycle Measurement.....	15
4-9.Type K Temperature Measurement.....	16
4-10.IR Temperature Measurement.....	17
4-11.Non-Contact AC Voltage Measurement.....	18
5.Battery Replacement.....	19
6.Specifications.....	20
6-1.Technical Specifications.....	20
6-2.General Specifications.....	22

1. Safety

1-1. International Safety Symbols

-  This symbol, adjacent to another symbol or terminal, indicates the user must refer to the manual for further information.
-  This symbol, adjacent to a terminal, indicates that, under normal use, hazardous voltages may be present.
-  Double Insulation

1-2. Safety Notes

- Do not exceed the maximum allowable input range of any function.
- Do not apply voltage to meter when resistance function is selected.
- Set the function switch OFF when the meter is not in use.

WARNINGS

- Set function switch to the appropriate position before measuring.
- When measuring volts do not switch to current/resistance modes.
- When changing ranges using the selector switch always disconnect the test leads from the circuit under test.
- Do not exceed the maximum rated input limits.

CAUTIONS

- Improper use of this meter can cause damage, shock, injury or death, read and understand this user manual before operating the meter.
- Always remove the test leads before replacing the battery.
- Inspect the condition of the test leads and the meter itself for any damage before operating the meter, repair or replace any damage before use.
- Use great care when making measurements if the voltages are greater than 25VAC rms or 35VDC, these voltages are considered a shock hazard.
- Remove the battery if the meter is to be stored for long periods.
- Always discharge capacitors and remove power from the device under test before performing Diode, Resistance or Continuity tests.
- Voltage checks on electrical outlets can be difficult and misleading because of the uncertainty of connection to the recessed electrical contacts, other means should be used to ensure that the terminals are not "live".
- If the equipment is used in a manner not specified by the manufacturer, the protection provided by the equipment may be impaired.

2. Description

2-1. Meter Description

- | | |
|--|------------------------|
| 1-Non-Contact AC Voltage Indicator | 9-MODE/VFD Button |
| 2-Current Clamp | 10-MAX/MIN Button |
| 3-Non-Contact AC Voltage Indicator Light | 11-COM Input Jack |
| 4-LCD Display | 12-Positive Input Jack |
| 5-Clamp Trigger | 13-Flashlight |
| 6-Relative/Laser Button | 14-Laser Hole |
| 7-Data Hold/Flashlight Button | 15-IR Sensor |
| 8-Rotary Function Switch | 16-Battery Cover |

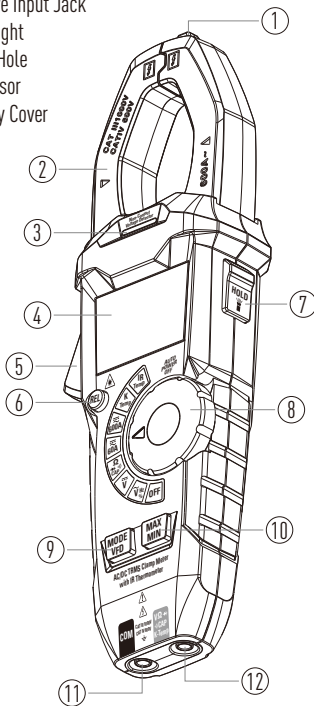
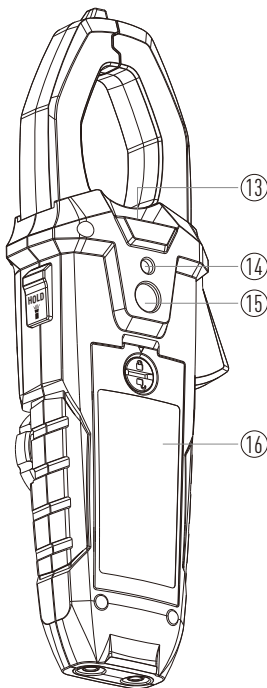

2-2.Symbols Used on LCD Display

- | | |
|-------------------|-------------------------------|
| 1-IR Laser Point | 10-Relative Mode |
| 2-Auto Power Off | 11-Low Battery |
| 3-Auto Range mode | 12-Measurement Display Digits |
| 4-Data Hold | 13-Units of Measure List |
| 5-Maximum | 14-Analog Bargraph |
| 6-Minimum | 15-Alternating Current |
| 7-VFD Mode | 16-Negative Reading Display |
| 8-Diode Test | 17-Direct Current |
| 9-Continuity Test | |

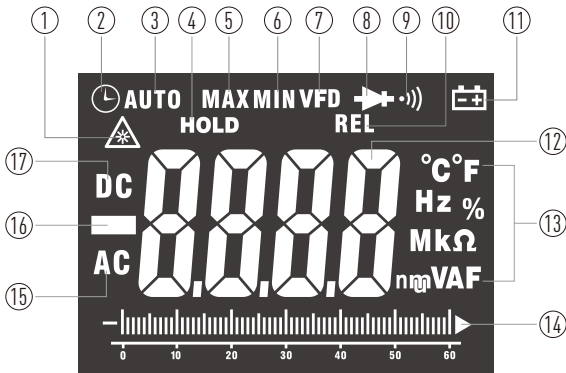

3.Button Function

3-1.Relative/Laser Button

- Press the **REL/Laser** Button to enter the relative value measurement mode, take the current value as the reference and obtain the relative value.
- In DCA mode, it can also be used as DCA zeroing.
- Long press the **REL/Laser** Button, you can turn on the laser to guide in IR-Temp measurement mode, and then press this Button to turn off the laser.

3-2.Data Hold/Flashlight Button

- To freeze the LCD meter reading, press the **Data Hold/Flashlight** Button, while data hold is active, the "HOLD" display icon appears on the LCD.
- Press the **Data Hold/Flashlight** Button again to return to normal operation.
- Long press the **Data Hold/Flashlight** Button to turn on the flashlight, then press the turn off flashlight.

3-3.MODE/VFD Button

- Press the **MODE/VFD** Button to select ACA/DCA, Diode/Continuity/CAP, VAC/Hz/%, °C/°F.
- In ACV mode, long press the **MODE/VFD** Button to enter VFD measurement mode and display VFD.
- In VFD mode, low-pass filter can reduce the high-frequency noise when measuring AC voltage.
- VFD mode is mainly used for AC voltage measurement of variable frequency drive and frequency converter.

3-4.MAX/MIN Button

- Press the **MAX/MIN** Button to enter MAX, MIN Recording mode (Manual range only).
- Select the proper range before selecting MAX MIN to ensure that the MAX/MIN reading will not exceed the testing range.
- Press once to select MIN, press again to select MAX and press again release MAX/MIN recording function.

4. Operation

Notes: Read and understand all **WARNING** and **Precaution** statements listed in the safety section of this operation manual prior to using this meter.

Notes: Set the function select switch to the OFF position when the meter is not in use.

4-1.AC/DC Current Measurement

WARNING: Ensure that the test leads are disconnected from the meter before making current clamp measurements.

1. Set the Function switch to the **600A** or **60A** AC/DC range, if the range of the measured is not known, select the higher range first then move to the lower range if necessary.
2. Press the **MODE/VFD** Button to switch the AC or DC measurement.
3. Press the trigger to open jaw, fully enclose one conductor to be measured.
4. The clamp meter LCD will display the reading.

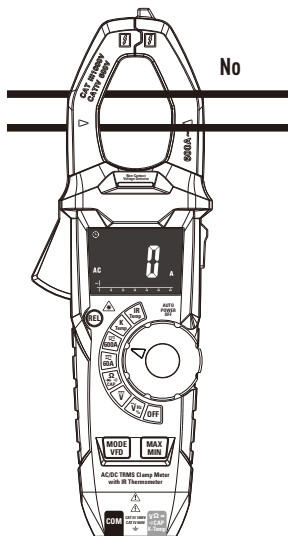
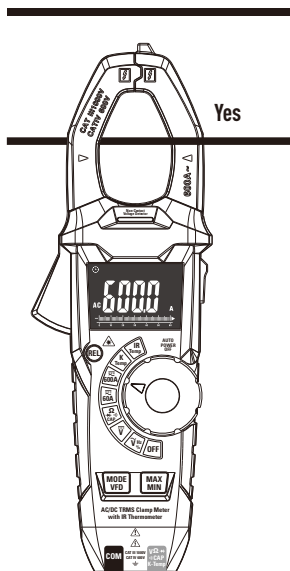

4-2. DC Voltage Measurement

1. Set the function switch to the **VDC** Position.
2. Insert the black test lead into the **COM** Input Jack and the red test lead into the **Positive** Input Jack.
3. Connect the test leads in parallel to the circuit under test.
4. Read the DC Voltage measurement on the LCD display.

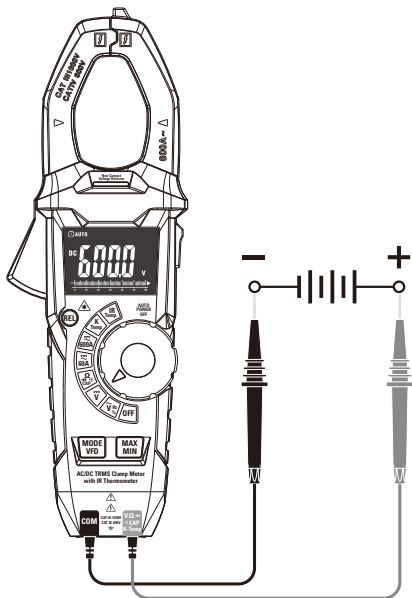

4-3.AC Voltage Measurement

- 1.Set the function switch to the **VAC/Hz%** Position.
- 2.Insert the black test lead into the **COM** Input Jack and the red test lead into the **Positive** Input Jack.
- 3.Connect the test leads in parallel to the circuit under test.
- 4.Read the AC Voltage measurement on the LCD display.

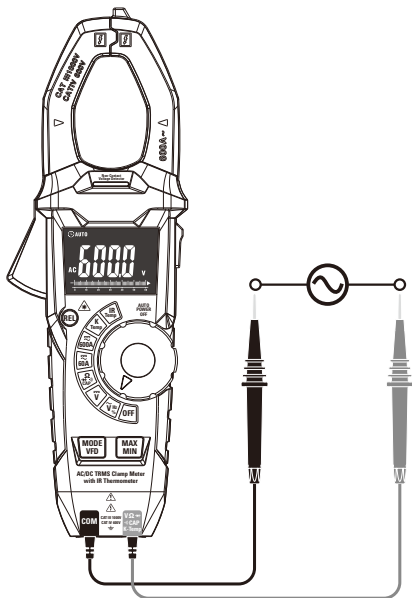

4-4. Resistance Measurement

1. Set the function switch to the $\Omega \rightarrow \rightarrow \rightarrow \text{CAP}$ Position.
2. Insert the black test lead into the **COM** Input Jack and the red test lead into the **Positive** Input Jack.
3. Press the **MODE/VFD** Button until “ Ω ” appears in the display.
4. Touch the test probe tips across the circuit or component under test, it is best to disconnect one side of the device under test so the rest of the circuit will not interfere with the resistance reading.
5. For Resistance tests, read the resistance on the LCD display.

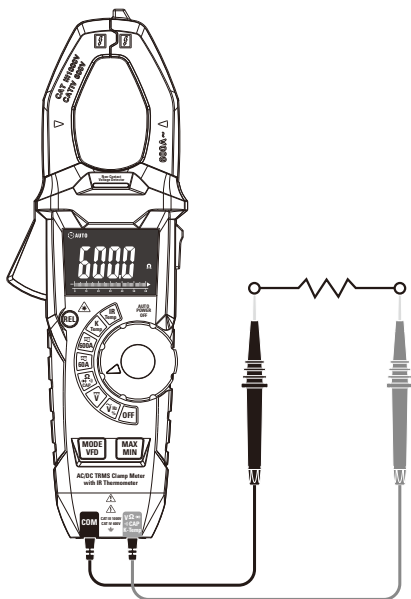

4-5. Diode Test

1. Set the function switch to the $\Omega \rightarrow \rightarrow \rightarrow$ CAP Position.
2. Insert the black test lead into the **COM** Input Jack and the red test lead into the **Positive** Input Jack.
3. Press the **MODE/VFD** Button until " \rightarrow " appears in the display.
4. Touch the test probes to the diode under test.
 - Forward voltage will indicate 0.4V to 0.7V, Reverse voltage will indicate "OL".
 - Shorted devices will indicate near 0mV and an open device will indicate "OL" in both polarities.

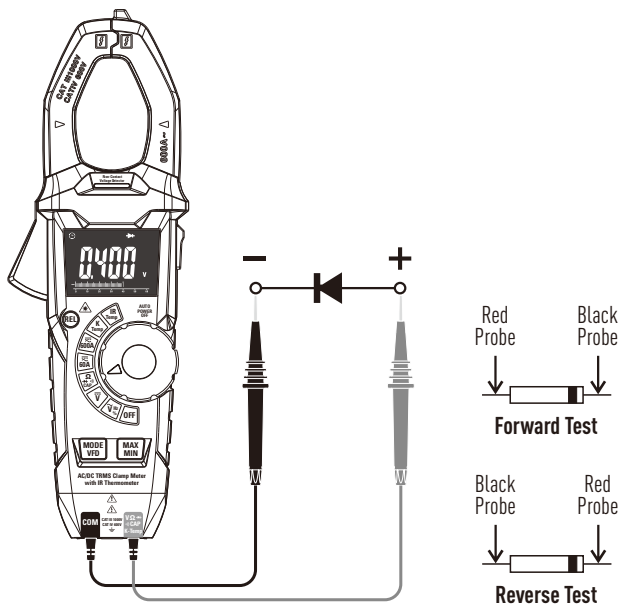

4-6. Continuity Measurement

1. Set the function switch to the $\Omega \rightarrow \text{蜂鸣}$ CAP Position.
2. Insert the black test lead into the **COM** Input Jack and the red test lead into the **Positive** Input Jack.
3. Press the **MODE/VFD** Button until “ 蜂鸣 ” appears in the display.
4. Touch the test probe tips across the circuit or component under test.
5. If the resistance is $<50 \Omega$, a tone will sound.

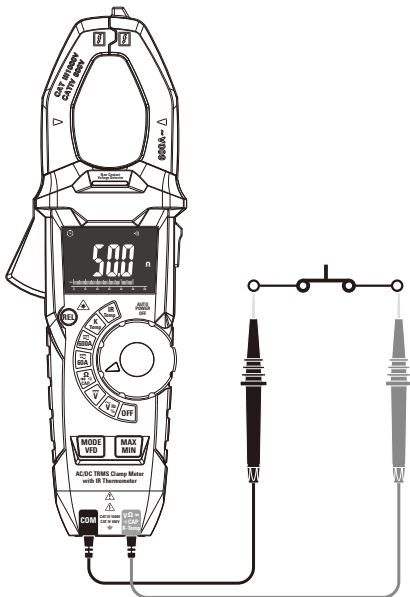

4-7.Capacitance Measurement

WARNING: To avoid electric shock, disconnect power to the unit under test and discharge all capacitors before taking any capacitance measurements. Remove the batteries and unplug the line cords.

- 1.Set the function switch to the $\Omega \rightarrow \rightarrow \rightarrow$ CAP Position.
- 2.Insert the black test lead into the **COM** Input Jack and the red test lead into the **Positive** Input Jack.
- 3.Press the **MODE/VFD** Button select capacitance measurement.
- 4.Touch the test leads to the capacitor to be tested.
- 5.Read the capacitance value in the display

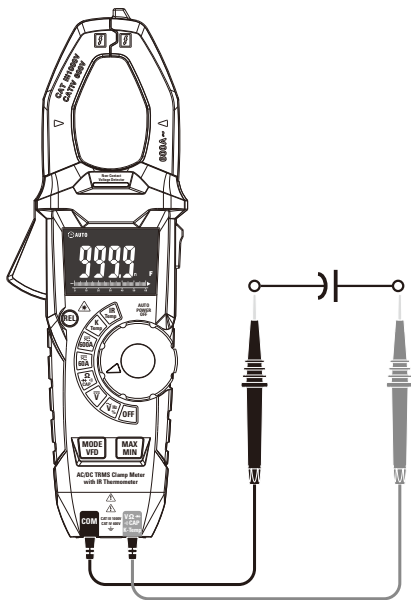

4-8. Frequency & % Duty Cycle Measurement

1. Set the function switch to the **VAC/Hz%** Position.
2. Insert the black test lead into the **COM** Input Jack and the red test lead into the **Positive** Input Jack.
3. Press **MODE/VFD** Button to select the Frequency (**Hz**) or Duty cycle (**%**).
4. Touch the test probe tips across the part under test.
5. Read the value on the display, the display will indicate the proper decimal point and value.

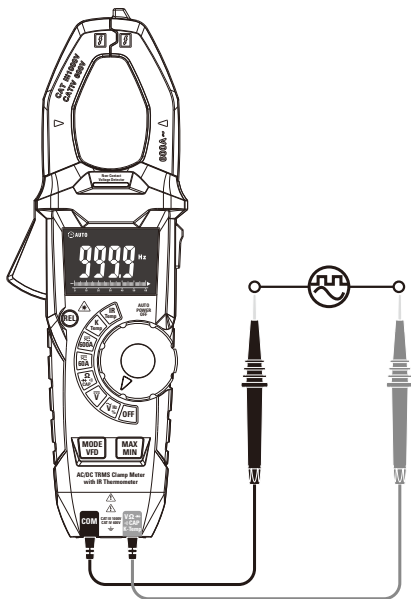

4-9. Type K Temperature Measurement

WARNING: To avoid electric shock, disconnect both test probes from any source of voltage before making a temperature measurement.

1. Set the function switch to the **K Temp** Position.
2. Insert the Temperature Probe into the **COM** and **Positive** Input Jack, making sure to observe the correct polarity.
3. Touch the Temperature Probe head to the part whose temperature you wish to measure, keep the probe touching the part under test until the reading stabilizes (about 30 seconds).
4. Read the temperature in the display, the digital reading will indicate the proper decimal point and value.

WARNING: To avoid electric shock, be sure the thermocouple has been removed before changing to another measurement function.

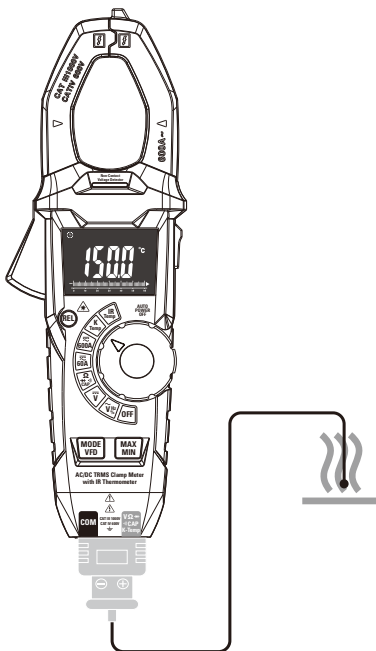

4-10. IR Temperature Measurement

1. Set the function switch to the **IR Temp** Position.
2. Let the instrument aim at the object which will be measured, the reading will display on the LCD.
3. Press the **REL/Laser** Button to switch on or off laser.
4. Press the **MAX/MIN** Button to select MAX/MIN, long press to exit.
5. Press the **Data Hold/Flashlight** Button, the data will freeze on the display, and then press to unfreeze.

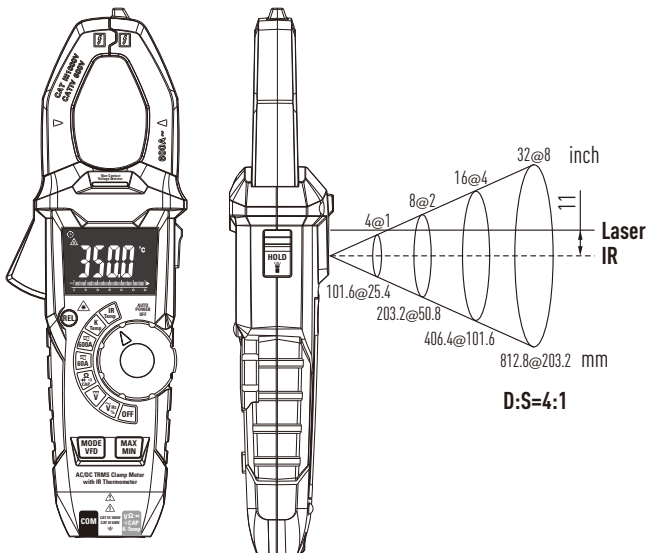

4-11. Non-Contact AC Voltage Measurement

WARNING: Risk of Electrocutation. Before use, always test the Voltage Detector on a known live circuit to verify proper operation.

1. Touch the probe tip to the hot conductor or insert into the hot side of the electrical outlet.
2. If AC voltage is present, the detector light will illuminate.

Note: The conductors in electrical cord sets are often twisted. For best results, rub the probe tip along a length of the cord to assure placing the tip in close proximity to the live conductor.

Note: The detector is designed with high sensitivity. Static electricity or other sources of energy may randomly trip the sensor, this is normal operation.

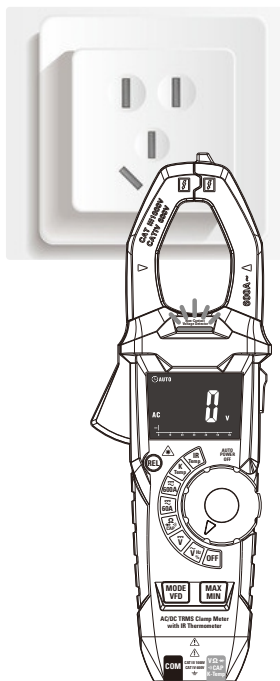

5. Battery Replacement

1. Remove the one rear head screw.
2. Open the battery compartment.
3. Replace the requires three "AAA" 1.5V Battery.
4. Re-assemble the meter.

6. Specifications

6-1. Technical Specifications

Function	Range	Resolution	Accuracy
DC Current	60A	0.01A	$\pm(2.8\% + 8 \text{ digits})$
	600A	0.1A	$\pm(2.8\% + 5 \text{ digits})$
AC Current (50/60Hz)	60A	0.01A	$\pm(1.5\% + 10 \text{ digits})$
	600A	0.1A	
DC Voltage	600mV	0.1mV	$\pm(0.8\% + 4 \text{ digits})$
	6V	0.001V	
	60V	0.01V	$\pm(1.2\% + 5 \text{ digits})$
	600V	0.1V	
	1000V	1V	
AC Voltage	6V	0.001V	$\pm(1.5\% + 5 \text{ digits})$
	60V	0.01V	
	600V	0.1V	
	1000V	1V	
Resistance	600 Ω	0.1 Ω	$\pm(1.5\% + 6 \text{ digits})$
	6k Ω	0.001k Ω	$\pm(2.0\% + 5 \text{ digits})$
	60k Ω	0.01k Ω	
	600k Ω	0.1k Ω	
	6M Ω	0.001M Ω	$\pm(2.8\% + 10 \text{ digits})$
	60M Ω	0.01M Ω	
Capacitance	999.9nF	0.1nF	$\pm(4\% + 6 \text{ digits})$
	9.999 μ F	0.001 μ F	
	99.99 μ F	0.01 μ F	
	999.9 μ F	0.1 μ F	
	9.999mF	0.001mF	$\pm(6\% + 15 \text{ digits})$
	99.99mF	0.01mF	

Function	Range	Resolution	Accuracy
Frequency	5 to 9.999Hz	0.001Hz	±(1.5% + 6 digits)
	99.99Hz	0.01Hz	
	999.9Hz	0.1Hz	
	9.999kHz	0.001kHz	

Sensitivity: >8Vrms

Duty Cycle	20.0% to 80.0%	0.1%	±(1.2% + 5 digits)
------------	----------------	------	--------------------

Sensitivity: >8Vrms

Type-K Temp	-20.0 to 1000°C	0.1°C	±(3% + 3°C)
	-4.0 to 1800°F	0.1°F	±(3% + 6°F)

Probe accuracy not included.

IR Temp	-30.0 to 350.0°C	0.1°C	±3°C at -30 to 0°C
			±2.0% or ±2°C at 0 to 350°C
	-22.0 to 662.0°F	0.1°F	±5°F at -22 to 32°F
			±2.0% or ±4°F at 32 to 662°F

D:S=4:1

Note: Accuracy is given as ±[% of reading+counts of least significant digit] at 23°C±5°C, with relative humidity less than 80%RH. The precision index mentioned above refers to the accuracy of 40%~60% range of each measurement range. The accuracy index of the current measured outside the measuring range increased by 1.5%, and the accuracy of other measurement functions increased by 1%. Check waveform is sine wave. Current accuracy assessment shall be based on the position of clamp center.

6-2. General Specifications

Clamp Size	Opening 1.3" (33mm) approx
TRMS	The AC voltage and ac current of this instrument are measured by TRMS, True RMS measurement is different from mean measurement. The mean measurement method can only measure the symmetric waveform, such as sine wave. True RMS measurements can reliably measure any irregular waveform and obtain valid values for AC voltage or AC current.
Diode Test	Test current of 0.3mA typical; Open circuit voltage 3.2V DC typical.
Continuity Check	Threshold $<50 \Omega$; Test current $< 0.5\text{mA}$
Low Battery Indication	"  "
Overrange Indication	"OL" is displayed
Measurements Rate	2 per second, Nominal
Input Impedance	$\geq 10\text{M} \Omega$ (VDC and VAC)
Display	6000 counts LCD
AC Current	50 to 60Hz (AAC)
AC Voltage Bandwidth	50 to 1000Hz (VAC)
Operating Temperature	5 to 40°C (41 to 104°F)
Storage Temperature	-20 to 60°C (-4 to 140°F)
Operating Humidity	Max 80% up to 31°C (87°F) decreasing linearly to 50% at 40°C (104°F)
Storage Humidity	$<80\% \text{RH}$
Operating Altitude	2000 meters (7000ft.) maximum.
Over Voltage	Category III 1000V, Category IV 600V
Battery	Three "AAA" 1.5V Battery
Auto OFF	Approx. 15minutes
Safety	For indoor use and in accordance with Overvoltage Category II, Pollution Degree 2. Category II includes local level, appliance, portable equipment, etc., with transient overvoltages less than Overvoltage CAT III.

Warranty

Triplett / Jewell Instruments extends the following warranty to the original purchaser of these goods for use. Triplett warrants to the original purchaser for use that the products sold by it will be free from defects in workmanship and material for a period of (1) one year from the date of purchase. This warranty does not apply to any of our products which have been repaired or altered by unauthorized persons in any way or purchased from unauthorized distributors so as, in our sole judgment, to injure their stability or reliability, or which have been subject to misuse, abuse, misapplication, negligence, accident or which have had the serial numbers altered, defaced, or removed. Accessories, including batteries are not covered by this warranty.

Copyright © 2023 Triplett
www.triplett.com

